

131094

07-17 JEEP JK - FRONT BUMPER KIT -  
STUBBY

**OFF CAMBER  
FABRICATIONS**

by: **MBRP** INC.

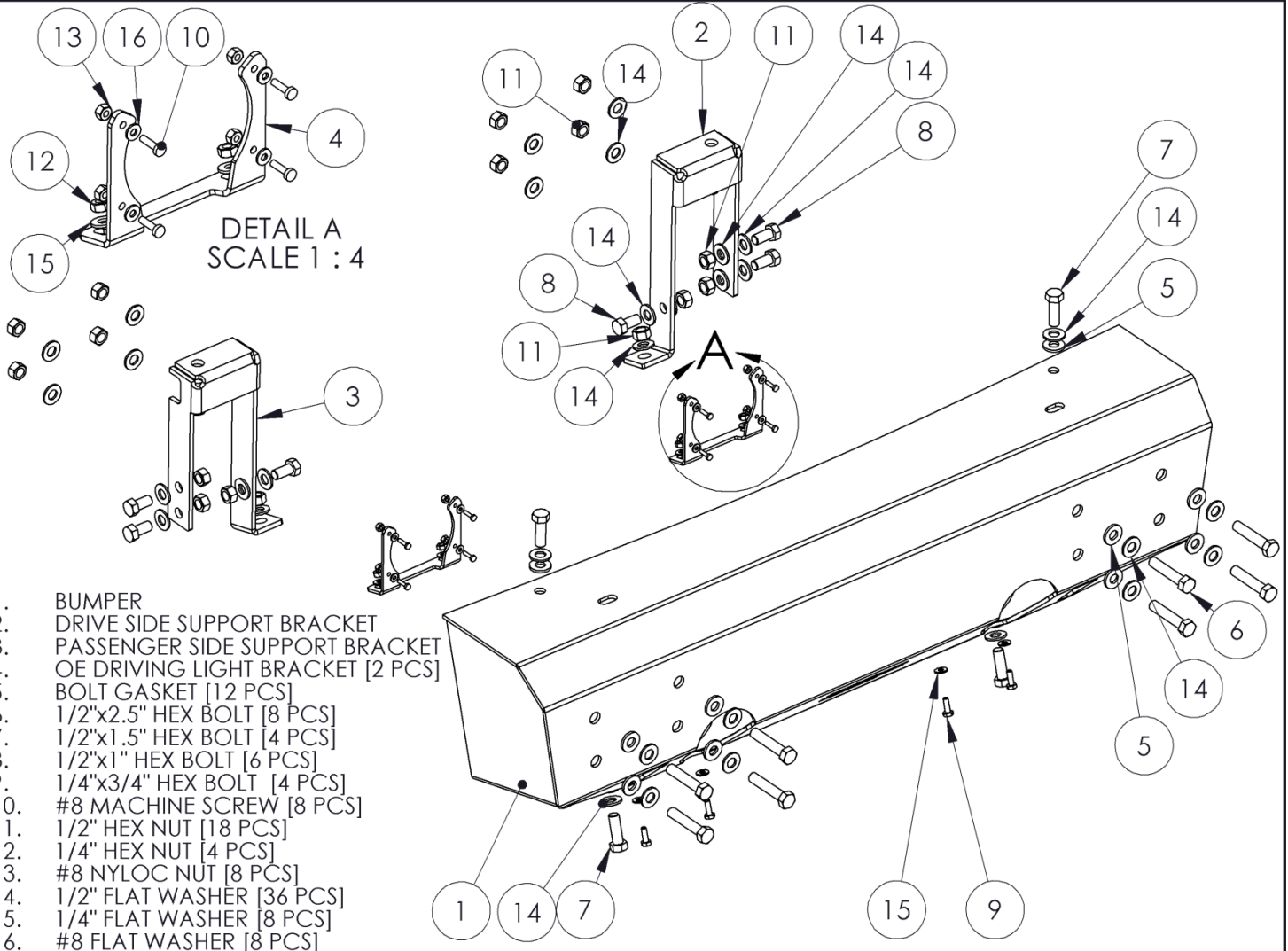

NOTE: 2012 AND UP REQUIRE VACUUM PUMP RELOCATE KIT #132032

## PLEASE READ BEFORE STARTING INSTALLATION

**While MBRP Inc. has made every effort to ensure that all components of this kit are of superior quality and properly packaged, it is the installer's responsibility to ensure the following before starting:**

- that ALL components shown above are present.
- that ALL mating components fit together.
- that there are no damaged components.
- that the kit you have purchased is appropriate for your year and model of vehicle.
- that the kit will not interfere with any modifications previously installed or planned.
- that you have read and understand these instructions.

If you have any questions or are uncertain about any aspect of the installation of this kit on your vehicle please contact your dealer before commencing installation.

## 2007-2017 Jeep JK Front Bumper Kit – Stubby

\*Note: Does not fit Hard Rock Edition

### Removing the OEM Bumper



Figure 1



Figure 2



Figure 3

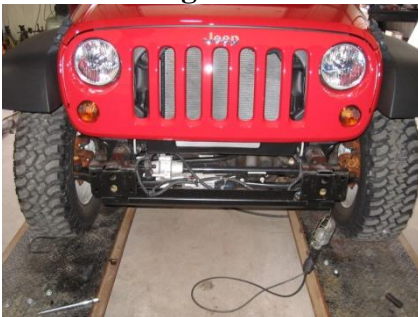

Figure 4

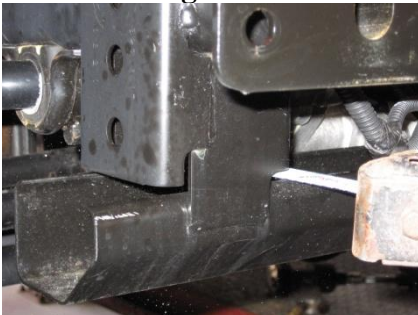

Figure 5

1. Remove the OE [Original Equipment] splash guard by removing the push rivets. **Refer to Figure 1.**

2. Remove the OE bumper by first unplugging the driving lights and then unclipping the wiring harness from the bumper crash bar. Then remove the eight nuts located on the frame horns. Once the eight nuts are removed, remove and retain the four backer plates. The bumper assembly will slide off. Remove the OE driving lights from the OE bumper. **Refer to Figure 2.**

3. Remove the two push rivets from the plastic filler panel between the OE bumper and the grill using a Phillips screwdriver to remove the core, and then pulling the rivets out. The core may spin without backing out. If this happens, try to pry up on the head of the rivet with a flat screwdriver while unscrewing the core. This will help the rivet pinch the threads of the core allowing removal. Once the rivets are out, remove the panel. This panel will not be reused. **Refer to Figure 3.**

4. The crossbrace connecting the LH and RH frame horns needs to be removed to provide clearance for the **Bumper**. Separate the crossmember using a sawsall or similar tool to cut the tabs as shown at each frame horn. Use a grinder to smooth the cut edges and seal with paint. **Refer to Figures 4 and 5.**



**Figure 1**



**Figure 2**



**Figure 3**



**Figure 4**



**Figure 5**

## **Installation of the Stubby Bumper**

1. Install the **Driver** and **Passenger Support Brackets** as shown above with the supplied  $\frac{1}{2}$ "x1" **Hex Bolts**,  $\frac{1}{2}$ " **Washers**, and  $\frac{1}{2}$ " **Hex Nuts**. The brackets must be installed exactly as shown with the lower tab facing the center of the vehicle and the open area at the upper through hole facing rearward. If the brackets are installed backwards the lower tabs will not line up with the lower face of the **Bumper**. Leave all fasteners loose enough to allow adjustment of the brackets in the following steps. **Refer to Figures 1 and 2.**

**NOTE:** On '11+ Jeeps, the upper outboard mounting hole for the **Frame Brackets** is not present. Position the **Frame Brackets** on the Frame and secure with the 2 mounting holes that do line up. Drill the 3<sup>rd</sup> hole with a  $\frac{1}{2}$ " drill bit and secure using the supplied hardware.

2. Mount both of the previously removed OE Driving Lights into the supplied **OE Driving Light Brackets** using the supplied #8x5/8" **Machine Screws**, #8 **Washers**, and #8 **Nyloc Nuts**. **Refer to Figure 3.**

3. Install both OE Driving Lights into the **Bumper** using the supplied  $\frac{1}{4}$ "x3/4" **Hex Bolts**,  $\frac{1}{4}$ " **Washers**, and  $\frac{1}{4}$ " **Hex Nuts**. **Refer to Figures 4 and 5.**



**Figure 6**



**Figure 7**

4. With help from a friend, install the **Bumper** onto the Jeep by sliding the assembly onto the frame horns and over both **Driver** and **Passenger Support Brackets**. The assembly can be temporarily pinned in place by installing the two  $\frac{1}{2}$ "x1.5" **Hex Bolts**,  $\frac{1}{2}$ " **Washers**, and **Bolt Gaskets** through the top surface of the **Bumper** into the **Driver** and **Passenger Support Brackets**. Some alignment of the brackets may be required. **Refer to Figure 6.**

**NOTE:** if you have purchased the optional **Light Bar Kit #131128**, it should be installed before Step 4.

5. Install the remaining fasteners to secure the **Bumper** starting by inserting the eight  $\frac{1}{2}$ "x2.5" **Hex Bolts**,  $\frac{1}{2}$ " **Washers**, and **Bolt Gaskets** through the front face of the **Bumper**. Secure on the backside by first reinstalling the OE backing plates followed by the supplied  $\frac{1}{2}$ " **Washers**, and  $\frac{1}{2}$ " **Hex Nuts**. Leave the fasteners loose. Do not tighten yet.

6. Install the two supplied  $\frac{1}{2}$ "x1.5" **Hex Bolts**,  $\frac{1}{2}$ " **Washers**, and **Bolt Gaskets** in the lower face of the **Bumper**. These bolts will pass through the lower tabs of the **Driver** and **Passenger Support Brackets**. Some alignment of the brackets may be required. Secure with the supplied  $\frac{1}{2}$ " **Hex Nuts** and  $\frac{1}{2}$ " **Washers**.

7. Secure the two  $\frac{1}{2}$ "x1.5" **Hex Bolts** and  $\frac{1}{2}$ " **Washers** installed in **Step 4** using the supplied  $\frac{1}{2}$ " **Hex Nuts** and  $\frac{1}{2}$ " **Washers**. Once all mounting fasteners are in place, tighten all  $\frac{1}{2}$ " fasteners to 60 ft-lbs in the following sequence.

- 8 bolts in the front face of the Bumper.
- 2 bolts in the top face of the Bumper.
- 2 bolts in the bottom face of the Bumper
- 6 bolts connecting the Driver and Passenger Support Brackets to the Frame.

8. Reconnect the Driving Light wiring and secure to prevent chaffing of the wiring.

Congratulations! You are finished. We are sure that you will enjoy This **Off Camber Fabrications** product by **MBRP Inc.**

